



# LUKE GOGGIN REAL ESTATE



## 19B Lester Street Sailors Gully VIC

3  1  2 

Currently tenanted until 1 September, this property will suit investors looking to buy into the popular Bendigo market. Step from the front porch into the entrance area which contains a handy storage cupboard. Follow through to the L shaped lounge, which could also accommodate a dining table & then into the kitchen/meals space. There are 3 bedrooms, all containing built in robes & a study off the main hallway. The bathroom is separated over 3 rooms - the toilet in one, the shower in another & the bath & vanity in the third. A good sized laundry includes storage & provides access to the spacious backyard with a garden shed & plenty of room for the pets or the kids to play. There's also a double carport at the front of the house. Close to schools, shops & transport this property could be cosmetically improved to add value.

**Price** : \$ 294,000  
**Land Size** : 633 sqm  
**View** : <https://www.goggin.com.au/sale/vic/greater-bendigo-region/sailors-gully/residential/house/6249130>



**Melinda Goggin**  
03 5442 1422

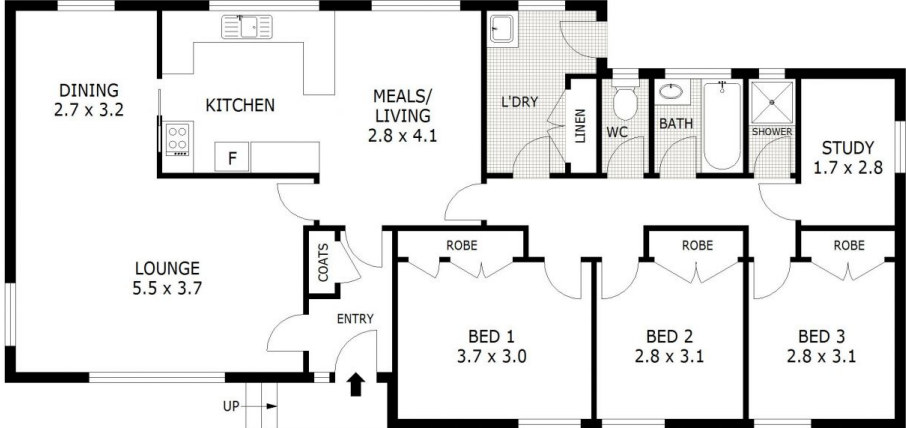
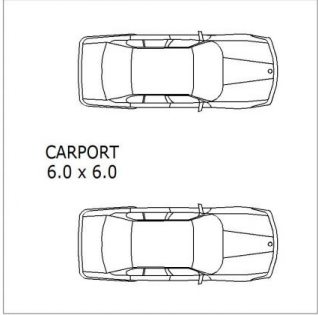
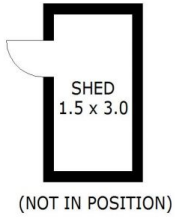

Scale in metres. Indicative only. Dimensions are approximate. All information contained herein is gathered from sources we believe to be reliable. However we cannot guarantee its accuracy and interested parties should rely on their own enquiries.

Residence	- 117 m <sup>2</sup>
Carport	- 36 m <sup>2</sup>
Shed	- 5 m <sup>2</sup>
<b>Total</b>	<b>- 158 m<sup>2</sup></b>



# 19B Lester Street, Sailors Gully